



Zignago Vetro



Zignago Vetro





Being a national and international leading company for over fifty years in the field of high quality glass packaging, Zignago Vetro SpA produces, in the two glassworks situated near Florence and Venice, over one and a half billion containers a year, which are directed to the Food & Beverage as well as to the Cosmetics & Perfumery markets.

Experience and deep knowledge of the glass manufacturing art, together with a constant renewing and anticipation of emerging trends, make Zignago's offer be the right match between a classical style and an original one and between reliability and innovation.

Its wide range for the Cosmetics & Perfumery includes containers for nail polish and for skin care, cream jars and perfume bottles.

Besides the realisation of private projects, Zignago Vetro is specialized in the research and development of standard products which are always available and ready to be customized according to customers' needs. The service is completed by the latest lacquering and printing solutions and by high quality accessories.

Zignago Vetro Group has been growing since 2002 thanks to the acquisition of Verreries Brosse SAS, premier French leading company in the production of high quality perfume bottles and of Huta Szkla Czechy in 2011, Polish glass factory, which offers a wide range of standard and customized containers for the Food & Beverage and for the Perfumery mass market.

Protagonista da oltre cinquant'anni del mercato nazionale e internazionale del packaging in vetro di alta qualità, Zignago Vetro SpA produce, nei suoi siti produttivi situati in prossimità di Firenze e Venezia, oltre un miliardo e mezzo di contenitori l'anno destinati ai settori delle Bevande & Alimenti e della Cosmetica & Profumeria.

L'esperienza e la profonda conoscenza dell'arte vetraria, il continuo rinnovamento e l'anticipazione delle nuove tendenze fanno sì che la proposta di Zignago sia la giusta coniugazione tra classicità e originalità, tra affidabilità ed innovazione.

La vasta offerta di contenitori per Cosmetica & Profumeria comprende flaconi per smalto, per la cura della pelle, vasetti per creme e flaconi per la profumeria.

Oltre allo sviluppo di progetti privati, Zignago Vetro propone un' ampia gamma di prodotti standard, sempre disponibili a magazzino e personalizzabili con le più innovative soluzioni di laccatura e serigrafia. La fornitura di accessori di alta qualità completa il servizio.

Nel 2002 il Gruppo Zignago Vetro si è ampliato con l'acquisizione della Verreries Brosse SAS, società francese leader nella produzione di flaconi e bottiglie di lusso per i mercati della profumeria e distilleria. Dal 2011 è venuta a far parte del Gruppo la Huta Szkla Czechy, società vetraria polacca specializzata nella produzione di flaconi standard e personalizzati destinati al mercato della Bevande & Alimenti e Profumeria mass market.



Nail Varnish
Smalti

pag. 7



Skincare
Curativi

pag. 49



Accessories
Accessori

pag. 71





Round 5

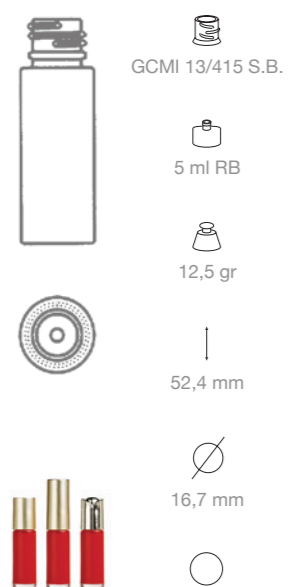

Sacramento



Botticelli 6,5



Botticelli 10

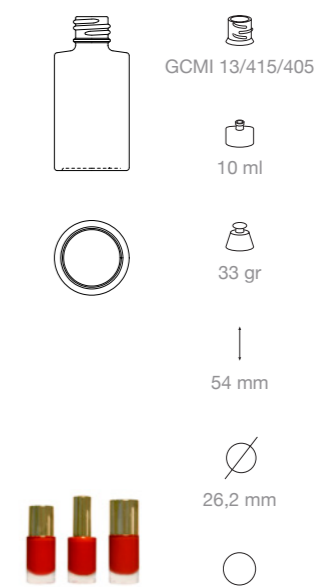



Trent 1/8

Trent 1/4

Trent 1/2

Grey

Trentino

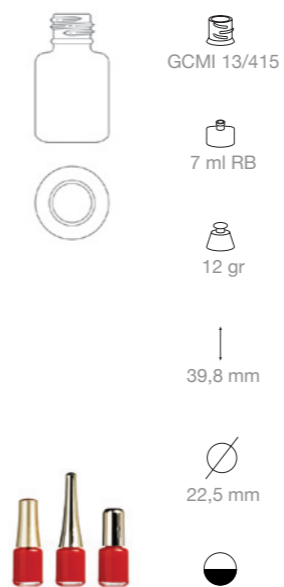
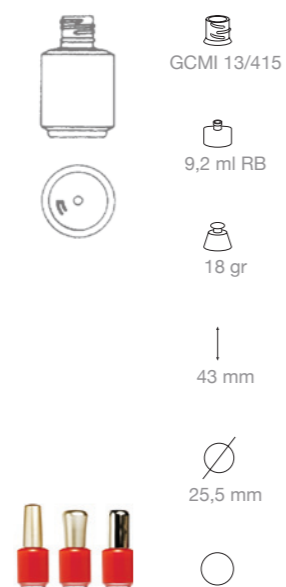
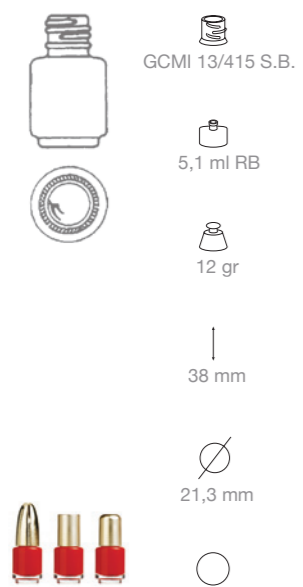



Thames 7

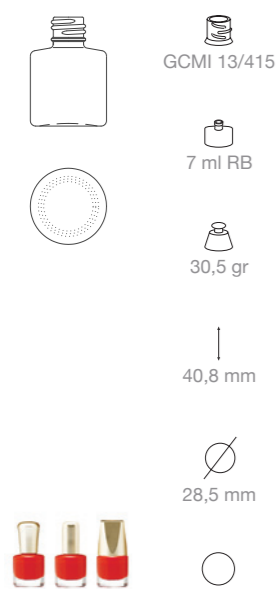

Thames 10,5

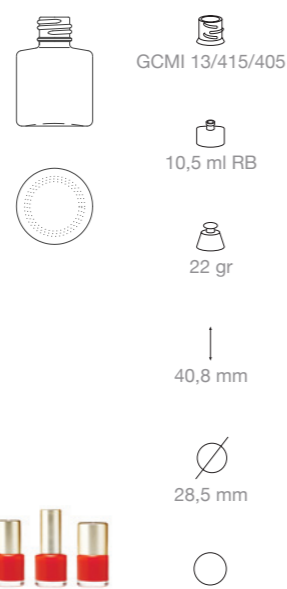

Thames 16

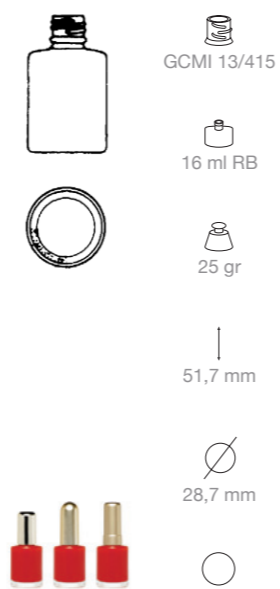

Moore

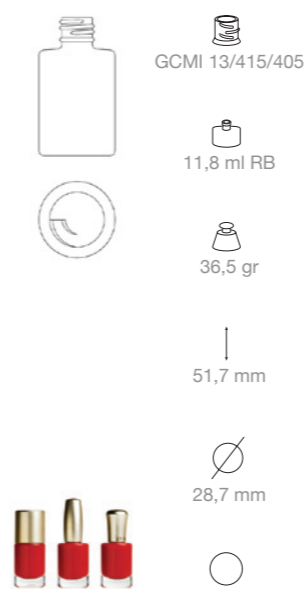

Seine 12





Tiepolo 10,5

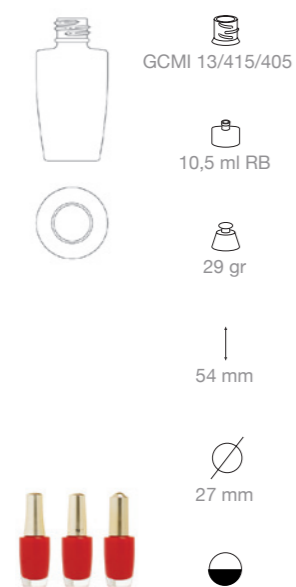

Tiepolo 12,5

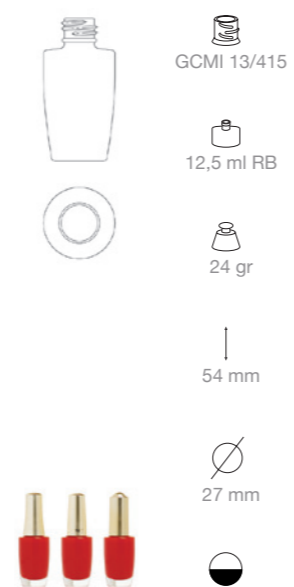

Valdor

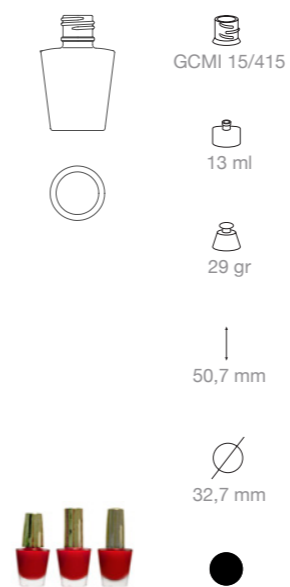

Lakes 1/2

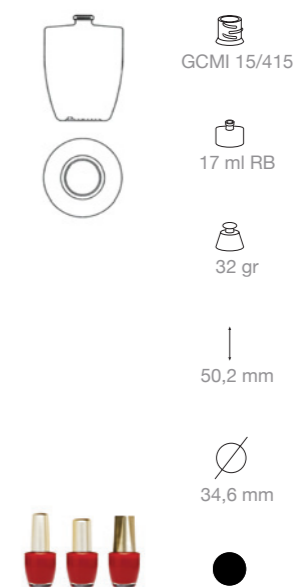



Picabia



Turner

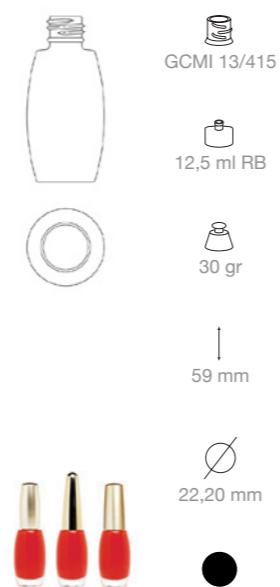

Lautrec



Music





Hudson



GCM1 13/415

11 ml RB

22 gr

50 mm

28,5 mm



Missisipi



GCM1 13/415

16 ml RB

26,5 gr

54,5 mm

31,4 mm



Oregon



GCM1 15/415

16,8 ml RB

28 gr

57 mm

32 mm



Liard 1/2



GCM1 13/415-405 S.B.

16,8 ml RB

28 gr

57,5 mm

29,3 mm





Dalì 5

Dalì 10

Dalì 13

Manet

Morris

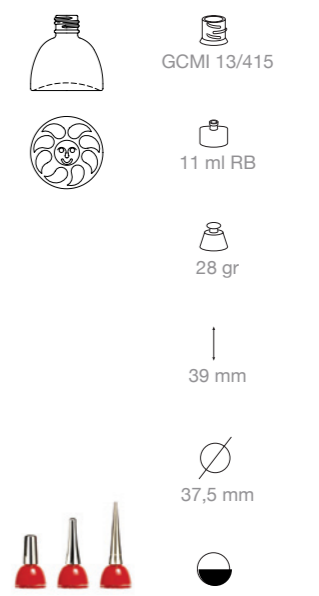
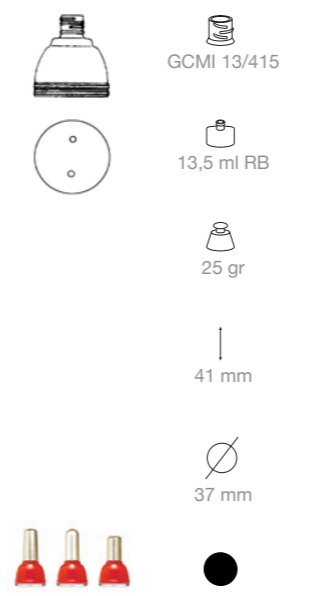
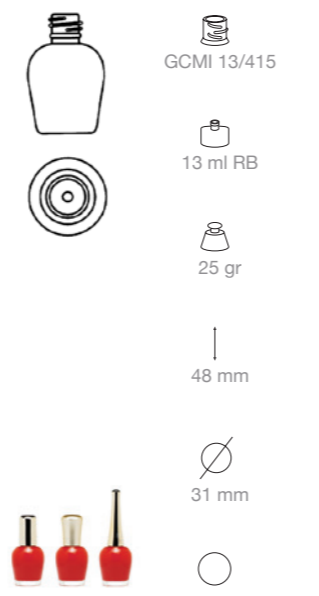
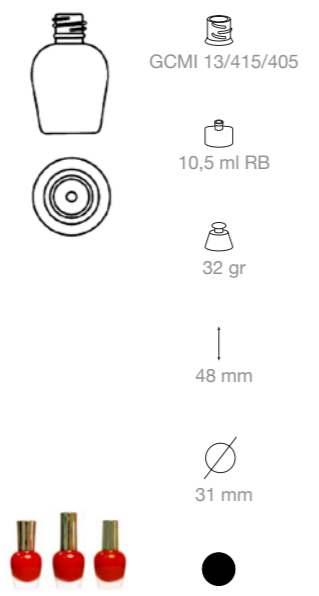
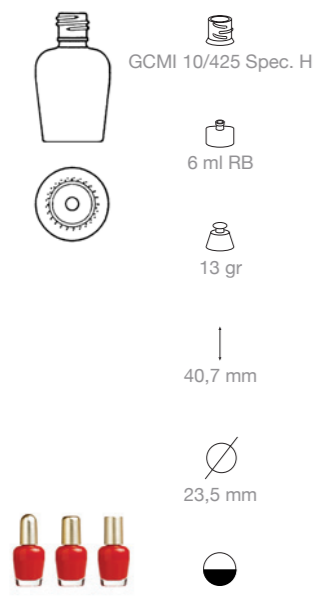



Snapper



GCMI 13/415

15,6 ml RB

25,4 gr

46,5 mm

38x26 mm



Sphere 1/2



GCMI 13/415 Spec. H

16,6 ml RB

25 gr

46,4 mm

36,4 mm



Goya 6,5



GCMI 10/425 Spec. H

6,5 ml RB

14 gr

44,6 mm

26,5x20 mm



Goya 14



GCMI 13/415

14,5 ml RB

28 gr

56,1 mm

34,6x23,6 mm





Carpaccio



Arp 12



Raffaello

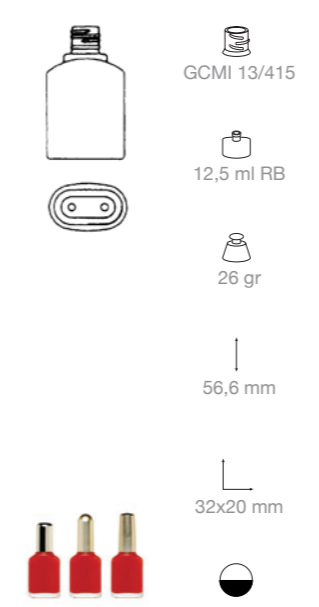

Veronese





Chagall

GCM1 10/425 Spec.

5,5 ml RB

13 gr

37,7 mm

25,3x16,3 mm

Gauguin

GCM1 13/415

10 ml RB

20 gr

44 mm

26,5x22 mm

Arno

GCM1 13/415/405

12,5 ml RB

25 gr

54,3 mm

34x19 mm

Man Ray

GCM1 13/415

12,7 ml RB

31 gr

54,4 mm

38x28,5 mm



Yazoo



GCM1 13/415

9 ml RB

23,5 gr

46,8 mm

36x17 mm



Watch 1/2

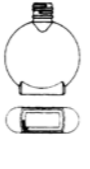

GCM1 13/415

14,6 ml RB

28,5 gr

57 mm

47x16,5 mm



Renoir



GCM1 13/415

13 ml RB

25 gr

43 mm

42x22 mm



Magritte



GCM1 13/415

13 ml RB

24 gr

45,1 mm

41,3x20,7 mm







Modigliani



GCM1 13/415



12 ml RB



24 gr

|

45 mm



21X38 mm



Corot



GCM1 13/415



12,2 ml RB



26 gr

|

45,7 mm



23,2X41,5 mm



Soutine

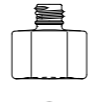

GCM1 13/415



11 ml RB



25 gr

|

34 mm



36,0 mm



Columbia



GCM1 13/415



16 ml RB



37 gr

|

45,6 mm



48x30 mm





Van Gogh

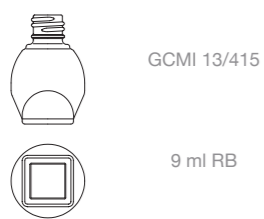

GCM1 13/415

9 ml RB

19 gr

42,5 mm

28,7 mm



Canova 16



GCM1 13/415

16 ml RB

30 gr

58,5 mm

32,2x21,2 mm



Ivy



GCM1 13/415

16 ml RB

32 gr

47,9 mm

48x21,7 mm



Platte



GCM1 15/415 Spec. H

16,8 ml RB

34 gr







56,9 mm

37,7x23,8 mm

















Yin e Yang

 GCM1 13/415
 9 ml RB
 22 gr
 42,6 mm
 37,4x21 mm







Tao 12

 GCM1 13/415
 11,5 ml RB
 28 gr
 42,6 mm
 38,5x23,5 mm

Sanday

 GCM1 13/415
 8,3 ml RB
 19 gr
 58,5 mm
 21x17,5 mm

Mosel

 GCM1 15/415/405
 16,3 ml RB
 26 gr
 54,2 mm
 27,5x23 mm











Osage 1/4









 GCM 13/415
 9 ml RB
 22,5 gr
 47,6 mm
 24X24 mm











Watteau

 GCM 13/415
 12 ml RB
 27 gr
 52,7 mm
 26X26 mm



Bellini

 GCM 13/415
 13 ml RB
 30 gr
 56 mm
 30,96x30,62 mm



Braque

 GCM 13/415
 12,5 ml RB
 32 gr
 42,5 mm
 28x37,2 mm





Rembrandt 12

Whistler 12

Kandinsky

Moreau

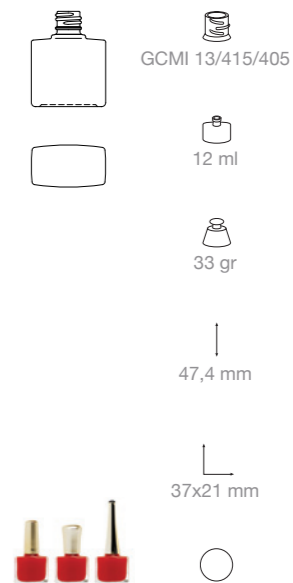
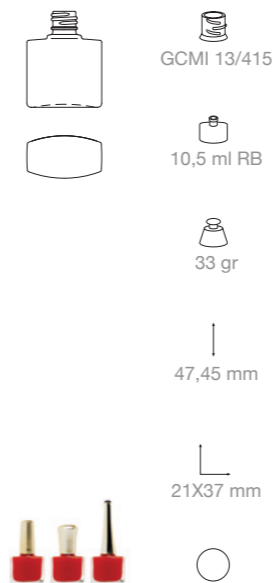
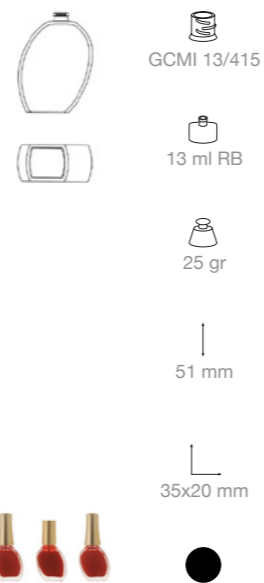
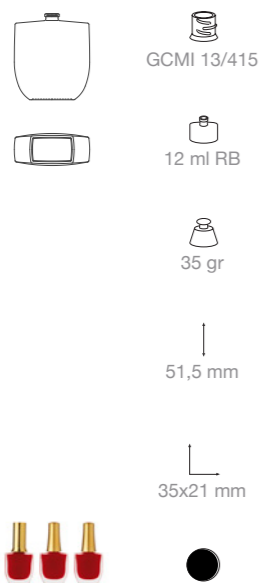



Lempicka 10,5

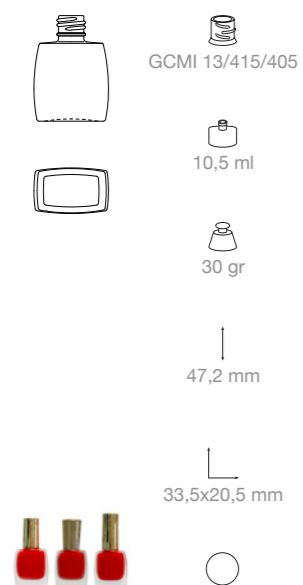

Villon



Square 5

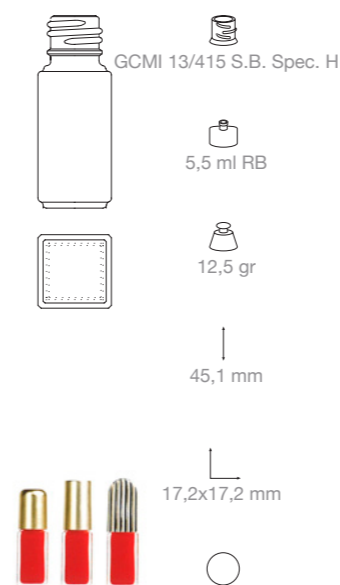

Delaware 8,8

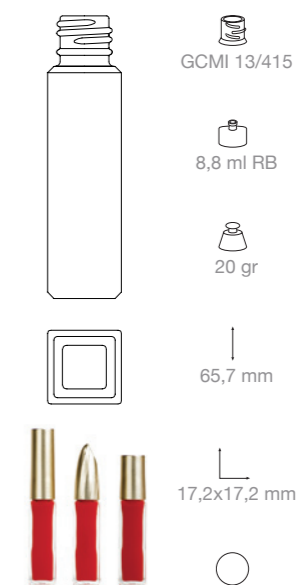



Clyde 9

Clyde 12

Clyde 17

Klimt 10,5

Klimt

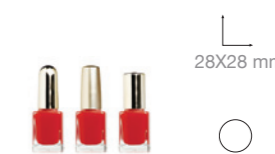
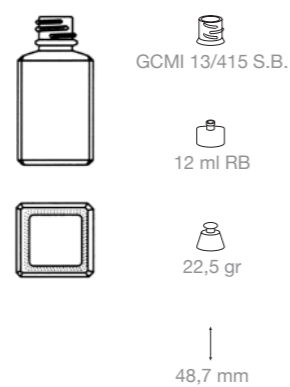
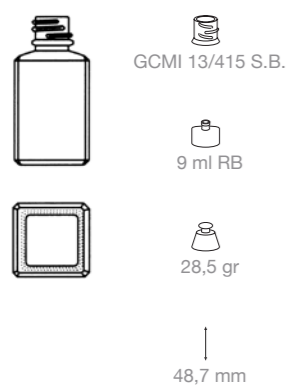



Rhone 6,5

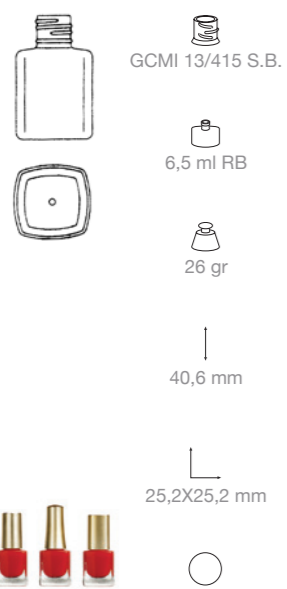

Rhone 1/4

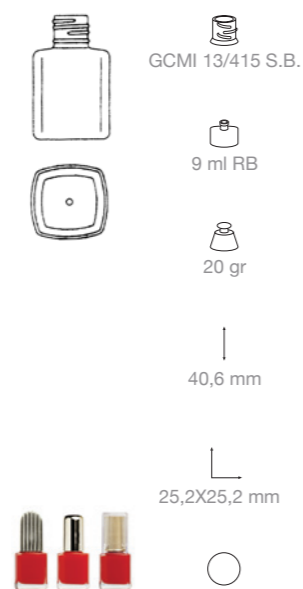

Rhone 1/2



Matisse

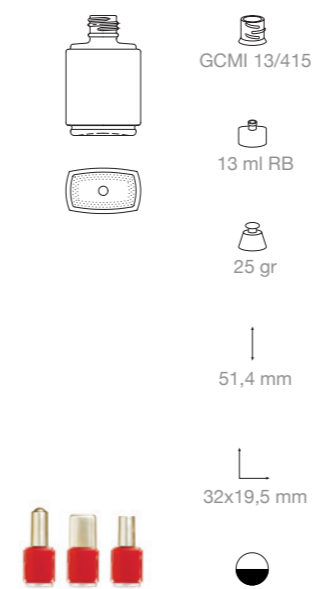

Colorado 3/8





Limay

Mantegna

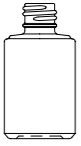

GCM1 13/415



12,6 ml RB



36 gr

51,5 mm



27x27 mm



GCM1 15/415



12,5 ml RB



39 gr

58,3 mm



25,4x25,4 mm







Round 5

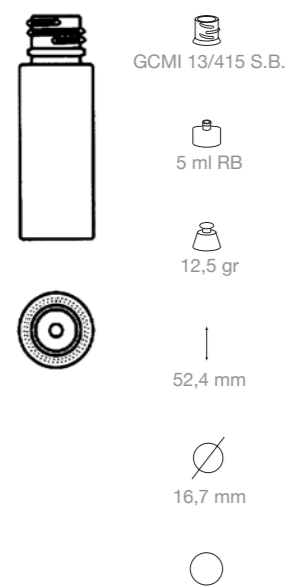

Sacramento

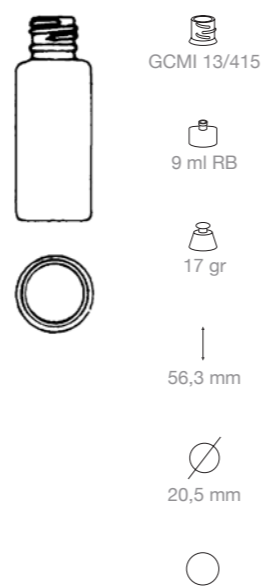

Gange 1/6

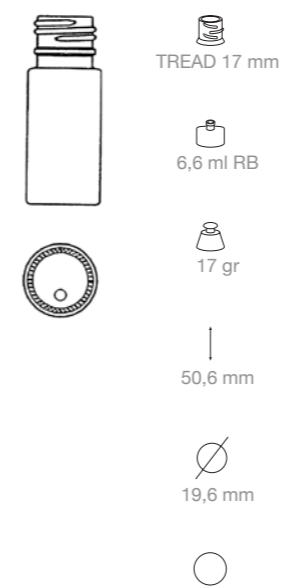

Gange 11

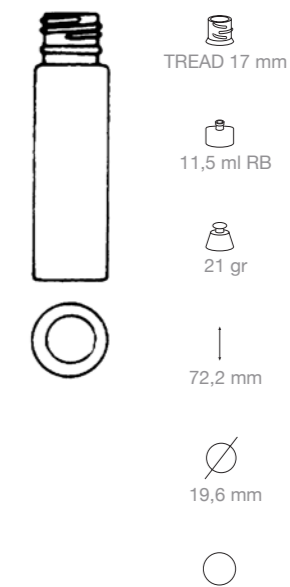



Thames 1/2 18/415

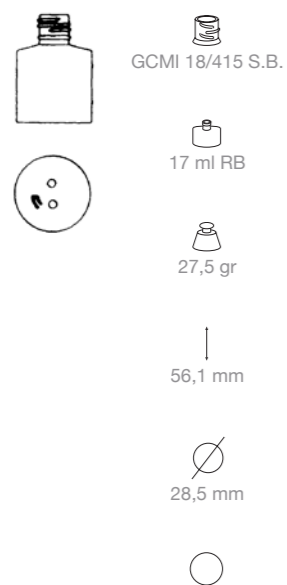

Thames 1



Rupert

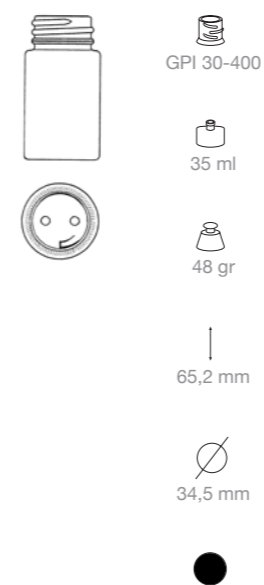

Round B. 50

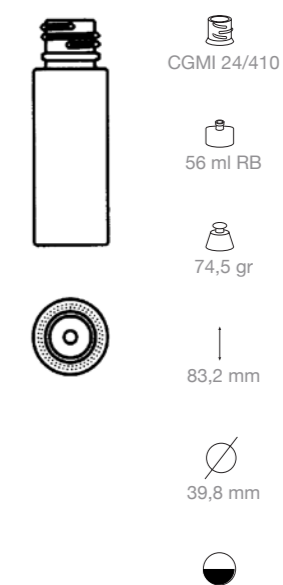



Van Dick 50

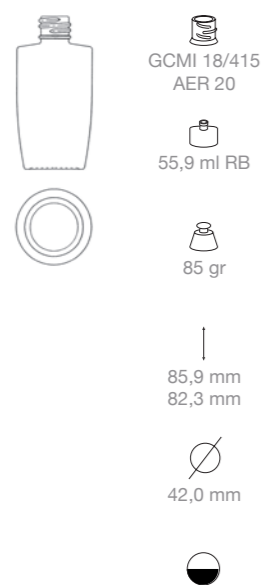

Van Dick 100



Tiber 1

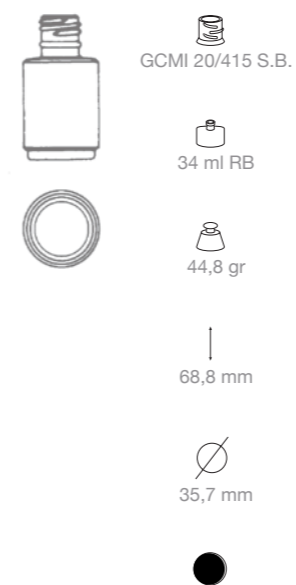

Roy 4 oz

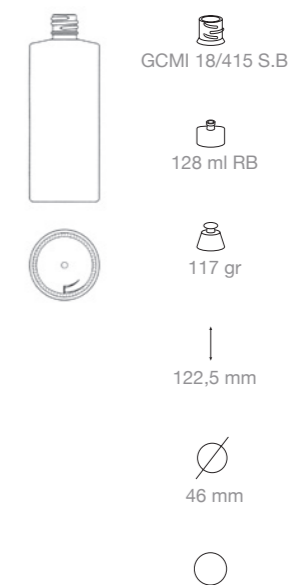



Dalì 30



Dalì 50



Dalì 100

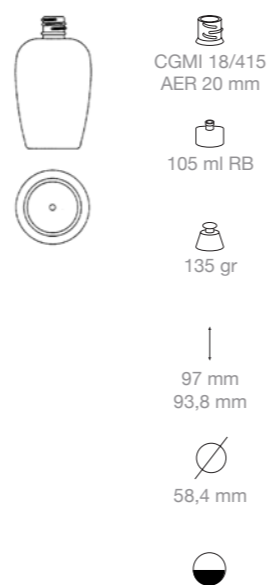

Makeup

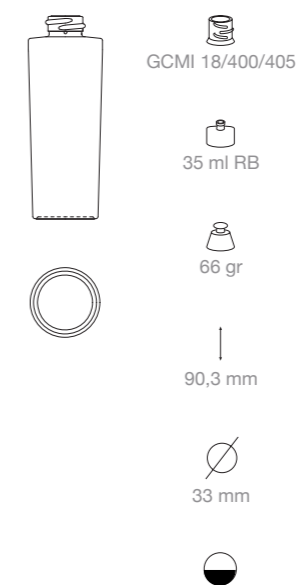



Goya 30

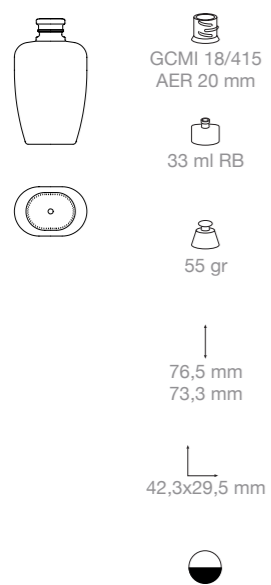

Goya 50

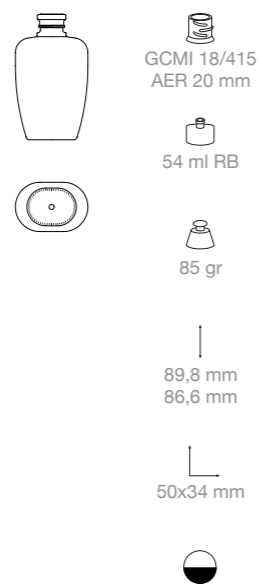

Goya 100

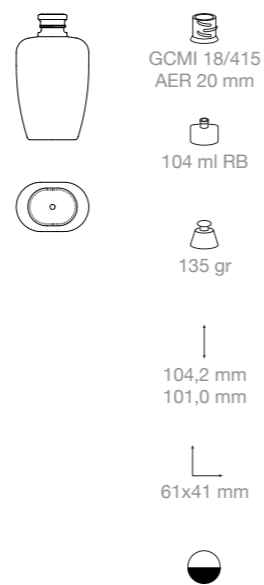

Arp 30

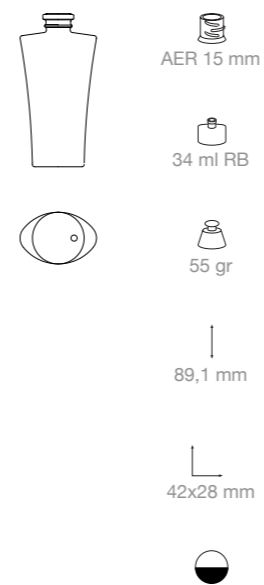

Arp 50

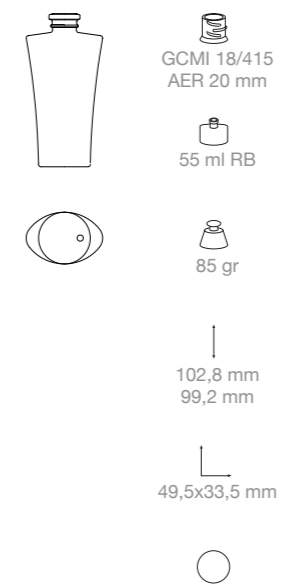

Arp 100





Clyde 1

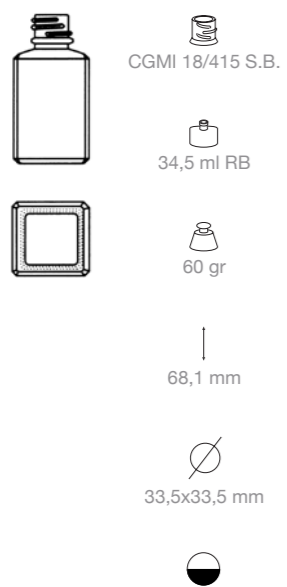

Caravaggio

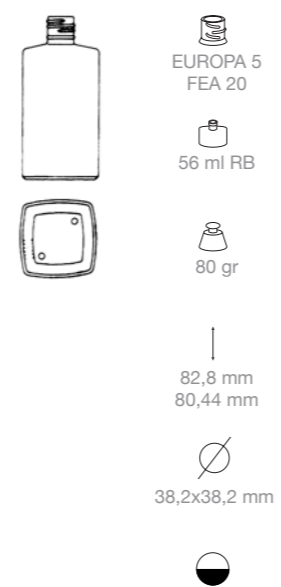

Pecos 30

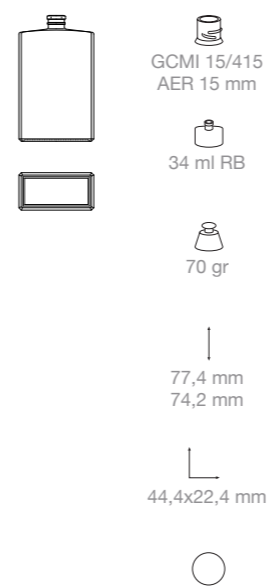

Pecos 50



Pecos 100





Klee 15

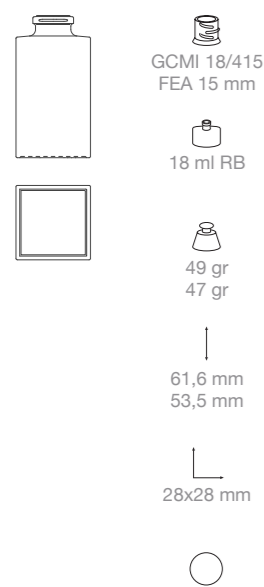

Klee 30

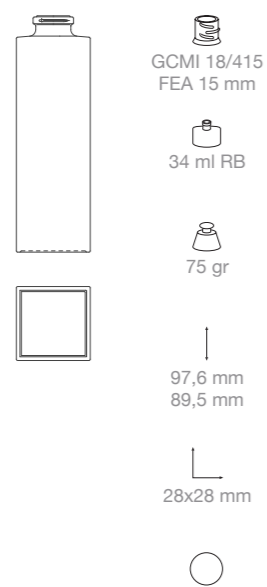

Klee 50

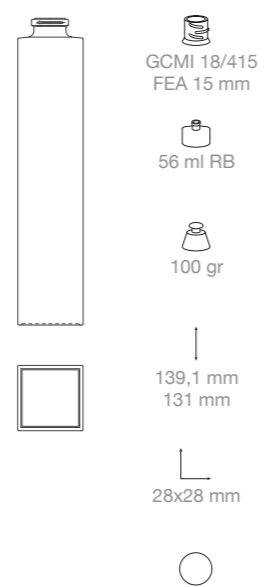

Klee 100

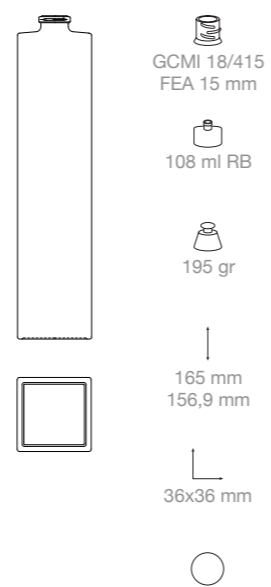

Rhone 1

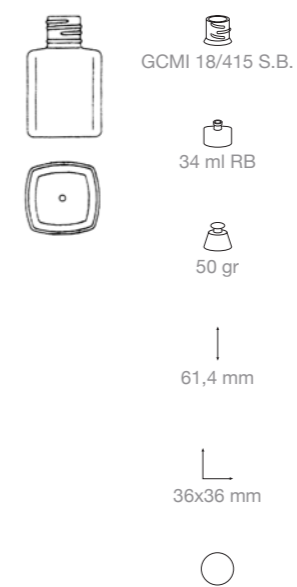



Nemi 1/2 oz

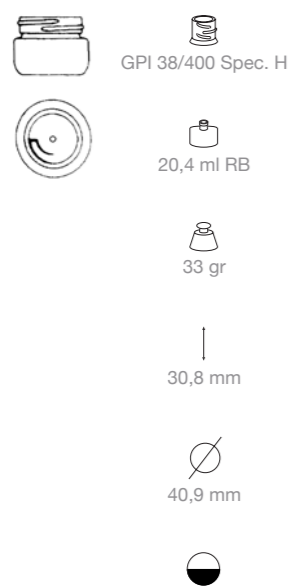

Nemi 2 oz

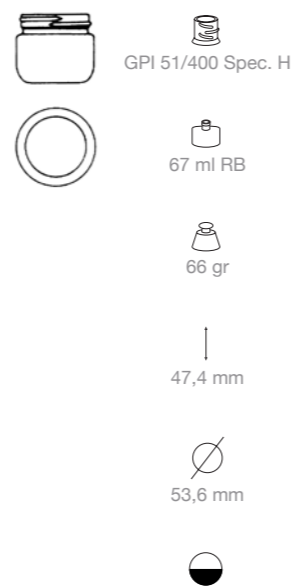

Bernini 15



Bernini 30





Licata

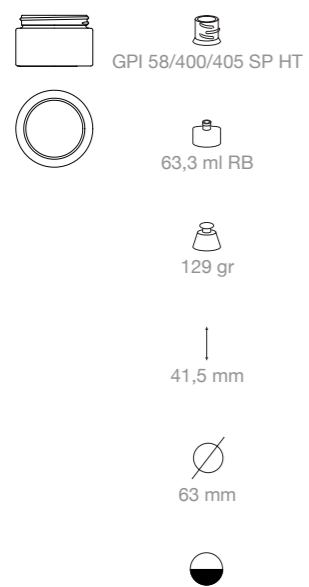

Lotto

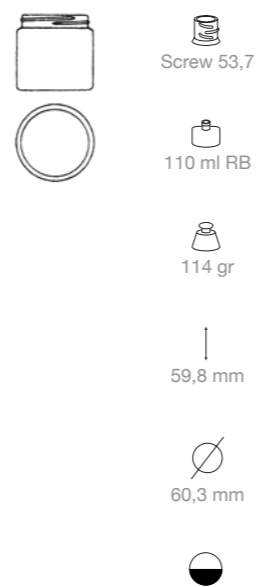

Rodin 50

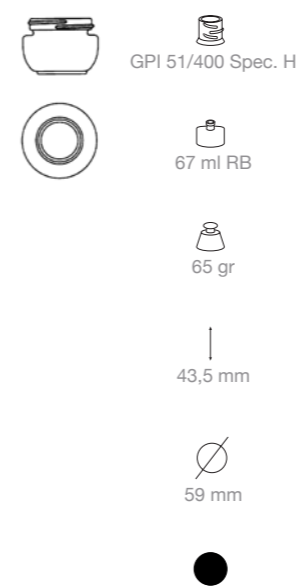

Donatello

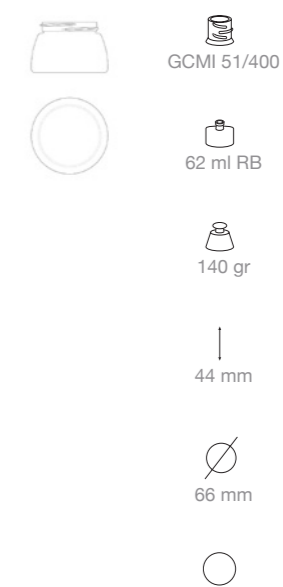



Palladio



Screw 49



39 ml RB

100 gr

40 mm

53 mm



Tiziano



Screw 55,2



66 ml RB

116 gr

45,8 mm

58,7 mm







Cupola 10

Lauderdale

Maui

Mosca

GCMi 10/425
 Tipo 10/62
 21,9 mm
 12,8 mm
M
 PP

GCMi 10/425
 Tipo 10/62
 18,8 mm
 13 mm
M
 PP

GCMi 10/425
 Tipo 10/62
 18,8 mm
 12,8 mm
M
 PP

GCMi 13/415
 Tipo 13/00
 16 mm
 19 mm
M
 PP



Torino Int.
Inj./light

Rossella

Moira

Moira Bassa

GCMi 13/415 GCMi 13/415
 Tipo LS Tipo LS
 28,75 mm 28,3 mm
 16,9 mm 16,2 mm
M **M**
 PP PP

GCMi 13/415
 Tipo LS
 28,5 mm
 20 mm
M
 PP

GCMi 13/415
 Tipo LS
 36 mm
 16,5 mm
M
 PP

GCMi 13/415
 Tipo LS
 30 mm
 16,65 mm
M
 PP



Grenada

Bastia

Minorca

Torino

GCMi 13/415
 Tipo S
 22 mm
 16 mm
M
 PP

GCMi 13/415
 Tipo S
 22 mm
 16 mm
M
 PP

GCMi 13/415
 Tipo S
 27,3 mm
 16,5 mm
M
 PP

GCMi 13/415
 Tipo S
 27,5 mm
 16,4 mm
M
 PP



Rome B

Rome B in
Interna/light

Cupola 13

Maiorca/
Maiorca int Inj

GCMi 13/415
 Tipo S
 35,50 mm
 16,6 mm
M
 PP

GCMi 13/415 GCMi 13/415
 Tipo LS Tipo LS
 36 mm 36,2 mm
 16,84 mm 16,25 mm
M **M**
 PP PP

GCMi 13/415
 Tipo LS
 35,5 mm
 16,5 mm
M
 PP

GCMi 13/415 GCMi 13/415
 Tipo S Tipo LS
 36 mm 36 mm
 16,5 mm 16,78 mm
M **M**
 PP PP



Istanbul

S. Diego

Venice/
Venice Int. Inj

Hannover

GCM1 13/415
Tipo S
37 mm
17 mm
M
PP

GCM1 13/415
Tipo AS
39 mm
18,5 mm
M
PP

GCM1 13/415 GCM1 13/415
Tipo LS Tipo LS
44 mm 43,43 mm
16,5 mm 16,85 mm
M M
PP PP

GCM1 13/415
Tipo LS
36,55 mm
16,95 mm
M
PP



Sparta

Laredo Matt

Gaudi

Athens

GCM1 13/415
Tipo LS
35,4 mm
18,4 mm
M
PP

GCM1 13/415
Tipo S
50 mm
19,5 mm
M
PP

GCM1 13/415
Tipo S
56 mm
19 mm
M
PP

GCM1 13/415
Tipo LS
57 mm
22,4 mm
M
PP



Barrel

Kendo

Kenia

Kendale 13

GCM1 13/415
Tipo LS
38,2 mm
16,2 mm
M
PP

GCM1 13/415
Tipo LS
36 mm
17 mm
M
PP

GCM1 15/415
Tipo LS
32 mm
21 mm
M
PP

GCM1 13/415
Tipo LS
36 mm
17 mm
M
PP



Chelsea

London/
London Int. Inj

Oxford

Cambridge

GCM1 13/415
Tipo S
29 mm
27 mm
M
PP

GCM1 13/415 GCM1 13/415
Tipo S Tipo LS
28,4 mm 29 mm
28,6 mm 28,1 mm
M M
PP PP

GCM1 13/415
Tipo LS
29,3 mm
25,5 mm
M
PP

GCM1 13/415
Tipo LS
26 mm
23 mm
M
PP



Lyon

Helena

Jersey

Okala

GCM1 13/415
 Tipo AS
 30 mm
 26 mm
M
 PP

GCM1 13/415
 Tipo AS
 29 mm
 21 mm
M
 PP

GCM1 15/415
 Tipo ELS
 31,5 mm
 19 mm
M
 PP

GCM1 15/415
 Tipo 15/117
 30,5 mm
 18 mm
M
 PP



Cupola 15

Brighton

Barcellona/Murcia

Cairo

GCM1 15/415
 Tipo ELS
 40 mm
 17,5 mm
M
 PP

GCM1 15/415
 ON SPATULA OR PLUG
 29 mm
 27,5 mm
M
 PP

GCM1 15/415
 PLUG
 28 mm
 22 mm
M
 PP

GCM1 15/415 - 18/415
 EUR 5
 -
 21,5/22 mm
 26 mm
M
 PP



S. Barbara

Olona/Olona inj. Int

Portland

Kendale 15

GCM1 15/415
 Tipo 15/117
 39,5 mm
 18,5 mm
M
 PP

GCM1 15/415 GCM1 15/415
 Tipo 15/117 Tipo 15/117
 36 mm 36,3 mm
 18,5 mm 18,08 mm
M **M**
 PP PP

GCM1 15/415
 Tipo 15/117
 36 mm
 18,5 mm
M
 PP

GCM1 15/415
 Tipo 15/117
 37 mm
 18 mm
M
 PP



Valencia

Toledo

Elba

Trenton

THREAD 17
 -
 26,6 mm
 19,4 mm
M
 SAN

GCM1 15/415
 ON SPATULA
 28 mm
 22 mm
M
 PP

ON ANCONA TRIESTE
 -
 29 mm
 19X19 mm
M
 ABS

ON ANCONA
 -
 31,5 mm
 21,75x21,75 mm
M
 ABS

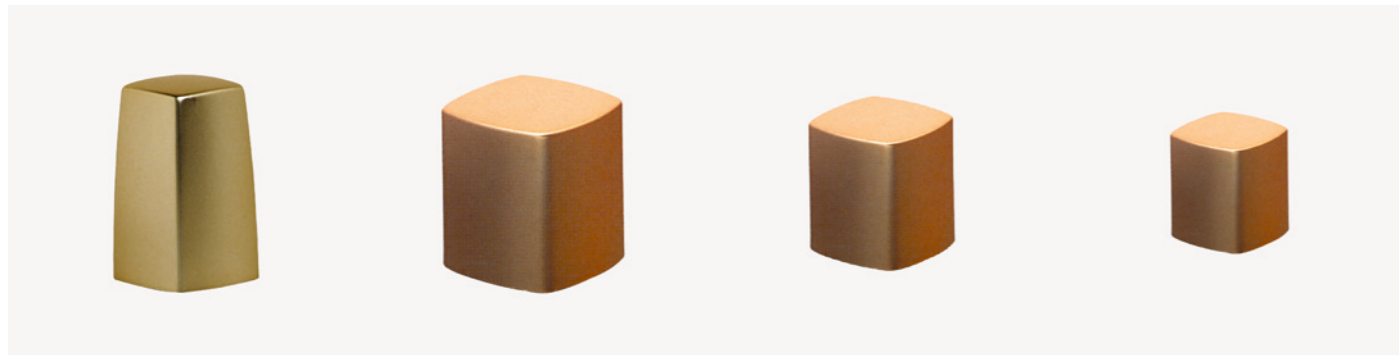

Watteau

Ischia

Ginepro 13

Ginepro 15

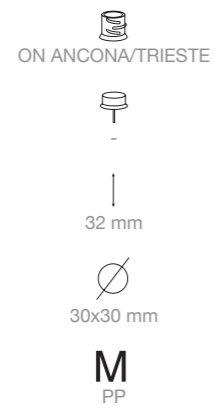

Pordenone

Margherita

Margherita arrotondata

Pervinca

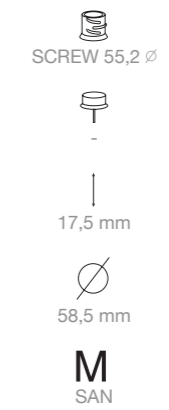

Matisse

Antares

Vulcano

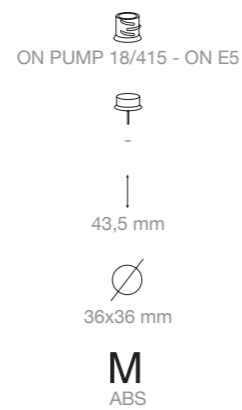
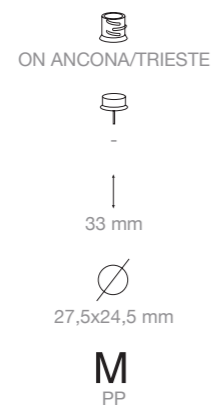
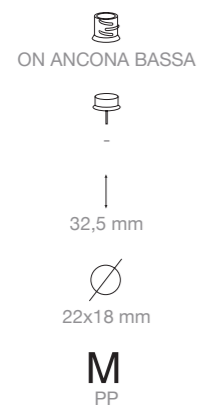

Pervinca arrotondata

Norwich

Cino

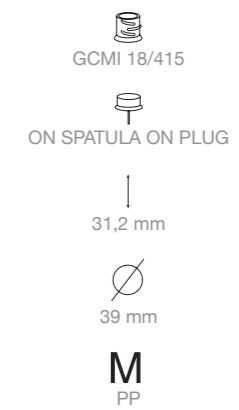



Spatole
Spatula

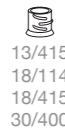

13/415
18/114
18/415
30/400

Fitments



On Gange bottle

Guarnizioni
Plugs



13/S-80
13/LS-96
13/AS-103
18/415
30/400



Pennelli
brushes

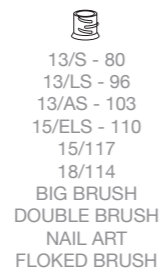

13/S - 80
13/LS - 96
13/AS - 103
15/ELS - 110
15/117
18/114
BIG BRUSH
DOUBLE BRUSH
NAIL ART
FLOKED BRUSH

ACCESSORIES
ACCESSORI

Antares	pag. 78
Athens	pag. 75
Barcelona/Murcia	pag. 77
Barrel	pag. 74
Bastia	pag. 72
Brighton	pag. 77
Cairo	pag. 77
Cambridge	pag. 75
Chelsea	pag. 75
Cino	pag. 79
Cupola 10	pag. 72
Cupola 13	pag. 73
Cupola 15	pag. 77
Elba	pag. 77
Fitments	pag. 80
Gaudi	pag. 75
Ginepro 13	pag. 78
Ginepro 15	pag. 78
Grenada	pag. 72
Guarnizioni	pag. 80
Hannover	pag. 74
Helena	pag. 76
Ischia	pag. 78
Istanbul	pag. 74
Jersey	pag. 76
Kendale 13	pag. 74
Kendale 15	pag. 76
Kendo	pag. 74
Kenia	pag. 74
Laredo Matt	pag. 75
Lauderdale	pag. 72
London/ London Int. Inj	pag. 75
Lyon	pag. 76
Maiorca/ Maiorca int Inj	pag. 73
Margherita	pag. 79
Margherita arrotondata	pag. 79
Matisse	pag. 78
Maui	pag. 72
Minorca	pag. 72
Moir	pag. 73
Moir Bassa	pag. 73
Mosca	pag. 72
Norwich	pag. 79
Okala	pag. 76
Olona/Olona inj. Int	pag. 76
Oxford	pag. 75
Pennelli	pag. 80
Pervinca	pag. 79
Pervinca arrotondata	pag. 79
Pordenone	pag. 79
Portland	pag. 76
Rome B	pag. 73
Rome B in Interna/light	pag. 73
Rossella	pag. 73
S. Barbara	pag. 76
S. Diego	pag. 74
Sparta	pag. 75
Spatole	pag. 80
Toledo	pag. 77
Torino	pag. 72
Torino Int. Inj./light	pag. 73
Trenton	pag. 77
Valencia	pag. 77
Venice/ Venice Int. Inj	pag. 74
Vulcano	pag. 78
Watteau	pag. 78

LEGEND LEGENDA

 **Type of finish**
Tipo di imboccatura

 **Capacity**
Capacità

 **Glass weight**
Peso vetro

 **Total height**
Altezza totale

 **Maximum diameter**
Diametro massimo

 **Item normally available**
Articolo normalmente disponibile

 **Item available in scheduled periods of time**
Articolo normalmente disponibile in periodi programmati

 **Item available only on order and for minimum quantities**
Articolo disponibile solo su ordinazione e per quantitativi minimi

GENERAL NOTES NOTE GENERALI

Accessories are available to order only.

All dimensions and capacities shown in this catalogue are approximate and within tolerances stated in the technical drawings. We reserve the right to modify, cancel or replace any item shown in this catalogue, without prior notice.

Gli accessori sono disponibili solo su ordinazione.

Le dimensioni e la capacità dichiarate sono da intendersi approssimate alle tolleranze previste dai disegni tecnici. Modifiche e sostituzioni degli articoli presenti su questo catalogo possono avvenire senza nessun preavviso

PRODUCTS INDEX INDICE PRODOTTI

Arno	pag. 27	Platte	pag. 33
Arp 12	pag. 24	Raffaello	pag. 25
Arp 30	pag. 59	Rembrandt 12	pag. 38
Arp 50	pag. 59	Renoir	pag. 29
Arp 100	pag. 59	Rhone 1	pag. 63
Bellini	pag. 37	Rhone 1/2	pag. 44
Bernini 15	pag. 65	Rhone 1/4	pag. 44
Bernini 30	pag. 65	Rhone 6,5	pag. 44
Botticelli 6,5	pag. 9	Rodin 50	pag. 67
Botticelli 10	pag. 9	Round 5	pag. 8
Braque	pag. 37	Round 5	pag. 50
Canova 16	pag. 32	Round B. 50	pag. 53
Caravaggio	pag. 60	Roy 4 oz	pag. 55
Carpaccio	pag. 24	Rupert	pag. 53
Chagall	pag. 26	Sacramento	pag. 8
Clyde 1	pag. 60	Sacramento	pag. 50
Clyde 9	pag. 42	Sanday	pag. 35
Clyde 12	pag. 42	Seine 12	pag. 13
Clyde 17	pag. 42	Snapper	pag. 22
Colorado 3/8	pag. 45	Soutine	pag. 31
Columbia	pag. 31	Sphere 1/2	pag. 22
Corot	pag. 30	Square 5	pag. 41
Dali 5	pag. 20	Tao 12	pag. 34
Dali 10	pag. 20	Thames 1	pag. 52
Dali 13	pag. 20	Thames 1/2 18/415	pag. 52
Dali 30	pag. 56	Thames 7	pag. 12
Dali 50	pag. 56	Thames 10,5	pag. 12
Dali 100	pag. 56	Thames 16	pag. 12
Delaware 8,8	pag. 41	Tiber 1	pag. 55
Donatello	pag. 67	Tiepolo 10,5	pag. 14
Gange 1/6	pag. 51	Tiepolo 12,5	pag. 14
Gange 11	pag. 51	Tiziano	pag. 68
Gauguin	pag. 26	Trent 1/2	pag. 10
Goya 6,5	pag. 23	Trent 1/4	pag. 10
Goya 14	pag. 23	Trent 1/8	pag. 10
Goya 30	pag. 58	Trentino	pag. 11
Goya 50	pag. 58	Turner	pag. 16
Goya 100	pag. 58	Valdor	pag. 15
Grey	pag. 11	Van Dick 50	pag. 54
Hudson	pag. 18	Van Dick 100	pag. 54
Ivy	pag. 33	Van Gogh	pag. 32
Kandinsky	pag. 39	Veronese	pag. 25
Klee 15	pag. 62	Villon	pag. 40
Klee 30	pag. 62	Watch 1/2	pag. 28
Klee 50	pag. 62	Watteau	pag. 36
Klee 100	pag. 62	Whistler 12	pag. 38
Klimt	pag. 43	Yazoo	pag. 28
Klimt 10,5	pag. 43	Yin e Yang	pag. 34
Lakes 1/2	pag. 15		
Lautrec	pag. 17		
Lempicka 10,5	pag. 40		
Liard 1/2	pag. 19		
Licata	pag. 66		
Limay	pag. 46		
Lotto	pag. 66		
Magritte	pag. 29		
Makeup	pag. 57		
Manet	pag. 21		
Man Ray	pag. 27		
Mantegna	pag. 46		
Matisse	pag. 45		
Missisipi	pag. 18		
Modigliani	pag. 30		
Moore	pag. 13		
Moreau	pag. 39		
Morris	pag. 21		
Mosel	pag. 35		
Music	pag. 17		
Nemi 1/2 oz	pag. 64		
Nemi 2 oz	pag. 64		
Oregon	pag. 19		
Osage 1/4	pag. 36		
Palladio	pag. 68		
Pecos 30	pag. 61		
Pecos 50	pag. 61		
Pecos 100	pag. 61		
Picabia	pag. 16		



ZIGNAGO VETRO SPA
via Ita Marzotto 8, 30025 Fossalta di Portogruaro (VE), Italy
tel: +39 0421 246111 / fax : +39 0421 246401
www.zignagovetro.com / e-mail: info@zignagovetro.com

ZIGNAGO VETRO GROUP in USA
West coast : Tel. 925-756-7471 / e-mail: lb@zignagovetrogroup.com
East coast : Tel. 908-635-1161 / e-mail: db@zignagovetrogroup.com